

DC/DC Converter

60 Watt

60 SBB 110 D15 □□□

$V_{I\text{ nom}} = 72\text{ V}$
 $V_{I\text{ nom}} = 110\text{ V}$ $V_{O\text{ nom}} = \pm 15\text{ V}$ $I_{O1, O2\text{ nom}} = \pm 2.0\text{ A}$

SYMBOL	PARAMETER	TEST CONDITIONS	MIN	TYP	MAX	UNITS
INPUT						
V_I	Input voltage range		40		154	V
$V_{I\text{ min}}$	Converter shutdown				39.9	V
$V_{I\text{ max}}$	Converter shutdown		156		158	V
V_{Enable}	Enable Function, PIN d22 Reference potential: - V_I	Converter On: Enable = low $V_{\text{Enable}} \leq 0.8\text{ V}$, $I \leq 1.5\text{ mA}$ Converter Off: Enable = high $V_{\text{Enable}} \geq 3.0\text{ V}$, $I \leq -50\text{ }\mu\text{A}^*$	0		0.8	V
	Stand by current	$40\text{ V} \leq V_I \leq 154\text{ V}$, Enable = high			18	mA
I_O	Input current	No load $V_I = 154\text{ V}$, $I_{O1} = 0\text{ A}$, $I_{O2} = 0\text{ A}$ Nominal load $V_I = 72\text{ V}$, $I_{O1} = 2.0\text{ A}$, $I_{O2} = -2.0\text{ A}$ Nominal load $V_I = 110\text{ V}$, $I_{O1} = 2.0\text{ A}$, $I_{O2} = -2.0\text{ A}$ Nominal load $V_I = 40\text{ V}$, $I_{O1} = 2.0\text{ A}$, $I_{O2} = -2.0\text{ A}$		1.0 0.7	70	mA A A A
	Input current integral	$V_I = 154\text{ V}$			5	A ² s
$I_{O\text{ max}}$	Max. input switch on current $V_I \geq V_{I\text{ min}}$, $V_{\text{Enable}} \rightarrow \leq 0.8\text{ V}$	$I_{O1} = 2.0\text{ A}$, $I_{O2} = -2.0\text{ A}$ $\Delta t \leq 200\text{ ms}$			6	A
	Input fuse		10 A Pico Fuse			
C_I	Converter input capacitance				25	μF
	External line inductance				50	μH
	Reverse input protection	Parallel diode + internal fuse	1.5KE160A			

OUTPUT: Power Unit

$P_{O\text{ nom}}$	Output power	$40\text{ V} \leq V_I \leq 154\text{ V}$		60		W
$V_{O\text{ nom}}$	Output voltage adjustment, factory set	$40\text{ V} \leq V_I \leq 154\text{ V}$	± 14.9	± 15.0	± 15.1	V
ΔV_O	Load regulation	$40\text{ V} \leq V_I \leq 154\text{ V}$ $0\text{ A} \leq I_{O1, O2} \leq \pm 2.0\text{ A}$ $T_A = -40^\circ\text{C} \dots +85^\circ\text{C}$	$\pm 2.5\% V_{O\text{ nom}}$			V
$\Delta V_{O\text{ dyn.}}$	Load regulation dynamic	$40\text{ V} \leq V_I \leq 154\text{ V}$, Puls load: $20 - 80 - 20\% \times I_{O1, I_{O2\text{ nom}}}$			± 500	mV
t_{dyn}	Response time	$40\text{ V} \leq V_I \leq 154\text{ V}$, Puls load: $20 - 80 - 20\% \times I_{O1, I_{O2\text{ nom}}}$		1	2	ms
$V_{O\text{ rms}}$	Ripple	$40\text{ V} \leq V_I \leq 154\text{ V}$ Nominal load BW 300 kHz		100	150	mV
$V_{A\text{ pp}}$	Noise	$40\text{ V} \leq V_I \leq 154\text{ V}$ Nominal load BW 20 MHz			350	mV
t_{On}	Turn on time V_O	$50.4\text{ V} \leq V_I \leq 154\text{ V}$, $0\text{ A} \leq I_O \leq \pm 2.0\text{ A}$ Resistive load 1.) $V_I \geq V_{I\text{ min}}$, $V_{\text{Enable}} \rightarrow \leq 0.8\text{ V}$ 2.) $V_{\text{Enable}} \leq 0.8\text{ V}$, $V_I \rightarrow \geq V_{I\text{ min}}$	25		200	ms
t_{off}	Hold up time	$50.4\text{ V} \leq V_I \leq 154\text{ V}$, $V_{O\text{ min}} = \pm 14.25\text{ V}$ $0\text{ A} \leq I_{O1, 2} \leq \pm 3.5\text{ A}$	1.2			ms
	Overvoltage shutdown V_O	$40\text{ V} \leq V_I \leq 154\text{ V}$ $0\text{ A} \leq I_{O1, 2} \leq \pm 2.0\text{ A}$	Converter off: $V_{O1} + V_{O2} \leq 36\text{ V}$			
$I_{O1, O2}$	Output current	$40\text{ V} \leq V_I \leq 154\text{ V}$		± 2.0		A
	Output current limitation	$40\text{ V} \leq V_I \leq 154\text{ V}$	± 2.1			A
	Output short circuit current $I_{O1, O2}$	Short circuit between + V_O and - V_O $40\text{ V} \leq V_I \leq 154\text{ V}$			2.5	A
	Cross load	one sided loaded + / - V_O	100% realising			
	Cross regulation, V_O	+ 15 V: $100\% \times I_O$, - 15 V: $0\% \times I_O$ + 15 V: $0\% \times I_O$, - 15 V: $100\% \times I_O$	± 14.7	± 15.0	± 15.3	V
	Cross regulation, short circuit current	100% load ($I_{O1, O2}$)			8.1	A
	Sense lines	Max. voltage drop compensation			0.25	V
C_O	Output capacity converter	Output each output stage		5		mF

OUTPUT: Signals

PF	Power Fail, PIN z20 Open Collector Transistor $V_{CE\text{ max}} \leq 70\text{ V}$, $I_{CE\text{ max}} \leq -20\text{ mA}^*$ Reference potential: - Sense	Transistor on: PF= low, $V_O < V_{O\text{ min}}$ Transistor off: PF= high, $V_O \geq V_{O\text{ min}}$	$V_O < 0.95 \times V_{O\text{ nom}} \pm 2\%$ $V_O \geq 0.95 \times V_{O\text{ nom}} \pm 2\%$	V V
	Signals	Signal defined for $V_O \geq 0.6 \times V_{O\text{ nom}}$		LED yellow On

GENERAL SPECIFICATIONS

f	Switching frequency	$V_I = 110\text{ V}$, $I_{O1, O2} = \pm 2.0\text{ A}$		75		kHz
η	Efficiency	$50.4\text{ V} \leq V_I \leq 154\text{ V}$, $P_O \geq 0.7 \times P_{O\text{ nom}}$	84	86		%
	MTBF (SN 29500)	$V_I = 110\text{ V}$, $I_{O1, O2} = \pm 2.0\text{ A}$, $T_A = +40^\circ\text{C}$		500 000		h
	No load, short circuit proof		Continuously			

* - Sign: sink current

SYMBOL	PARAMETER	TEST CONDITIONS	MIN	TYP	MAX	UNITS
--------	-----------	-----------------	-----	-----	-----	-------

SAFETY / DIMENSIONS

	Creepage, Clearance PCB FR4 V0	Input – output Input – case Output – case	2.0 2.0 1.0			mm mm mm
	Converter dielectric strength test every unit ramp function 2 s – 3 s – 2 s	Input – output Input – case Output – case			2100 2100 750	VDC VDC VDC
	Connectors DIN 41612	H15, Pin 24 leading				
	Pin assignment			see table		
	Protection class, protection system			I, IP 20		
	Dimensions w x h x d see figure	Plug - in unit incl. front panel Wall mounting, Din rail mounting TS35	45.3 x 128.4 x 160 (9 T / 3 U) 217 x 104 x 71			mm mm
	Weight	Plug - in unit incl. front panel Wall mounting, Din rail mounting TS35		0.55 1.2		kg kg

ENVIROMENTAL CONDITIONS

T _A	Operating temperature range	Continuously EN 50155 Class Tx for 10 min. + 85°C	- 40 - 40		+ 70 + 85	°C °C
T _{Storage}	Storage temperature range		- 40		+ 85	°C
	Cooling		Free air convection			
	Humidity	EN 50155, IEC 60571	75% averaged year, 95% 30 days			
	Vibration / shock Valid for plug - in unit and wall mounting	IEC 61373, IEC 68-2-27, BN 411002 Cat. I 3 shocks per axes	50 m / s ² , 30 ms			

EMC

	Emission	Line conducted and radiated	EN 50121 - 3 - 2: 2001		
	Immunity	ESD EN 61000 - 4 - 2	6 kV / 8 kV Performance criteria - B -		
		High frequency field EN 61000 - 4 - 3	20 V / m 80 MHz ... 1 GHz Performance criteria - A -		
		Burst EN 61000 - 4 - 4	Level 3 asym., sym. Performance criteria - A -		
		Surge EN 61000 - 4 - 5	2 kV asym. / 1 kV sym. R _i = 42 Ω Performance criteria - A -		
		HF – Current injection EN 61000 - 4 - 6	3 V _{eff} , R _i = 150 Ω Performance criteria - A -		

STANDARDS

Applied Standards:	EN 50155: 2000	BN 411 002	EN 50124 - 1: 1996	EN 50121 - 3 - 2: 2001	IEC 60571
	SN 29500	prEN 50121 - 1	prEN 50125 - 1	EN 60068 - 2 - 6, 2...27	EN 61000 - 4 - 2...6
	IEC 571	IEC 61373: 1999	EN 60721 - 3 - 5	EN 61373: 1999	EN 60529

Technical specifications valid for: - 40° C ≤ T_A ≤ + 70° C, 50.4 V ≤ V_I ≤ 137.5 V, unless otherwise noted.

H15 – Pin Assignment

Pin	
z 4	+ Sense
d 6	+ V _O
z 8	0 Sense
d 10	GND
z 12	GND
d 14	- V _O
z 16	- Sense
d 18	n.c.
z 20	Power Fail
d 22	Enable
z 24	⏏
d 26	+ V _I
z 28	+ V _I
d 30	- V _I
z 32	- V _I

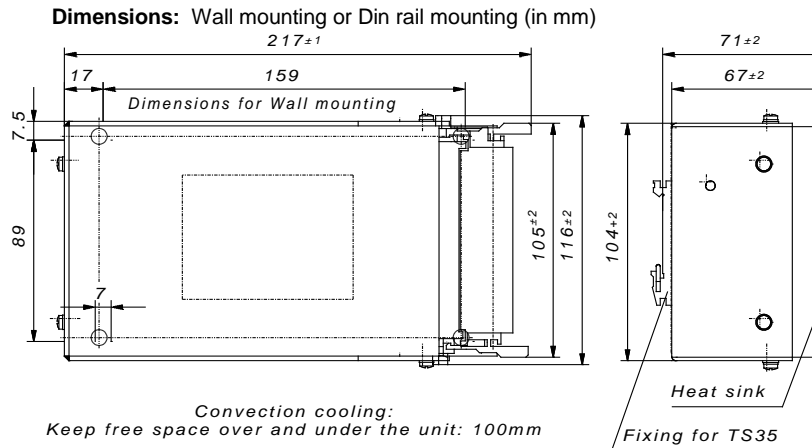

Order code: 60 SBB 110 D15 □0□ select

- x = individual customised front panel
- E = Plug - in unit
- W = Wall mounting
- H = Din rail mounting TS35